

Class action against Sorin GMBH and LivaNova Canada re Sorin 3T Heater Cooler Units

Information session for potential class
members about status of the proceeding

April 19, 2020, 4 pm EST



Who We Are

- Flaherty McCarthy LLP and Waddell Phillips Professional Corporation have partnered to pursue a proposed class action against Sorin Group Deutschland GMBH and LivaNova Canada Corp.
- [Flaherty McCarthy](#) is a prominent insurance litigation firm representing both individuals and insurers across Canada and the US. It has successfully acted on a number of important class actions including privacy breaches, exposure to disease, and consumer protection.
- [Waddell Phillips Professional Corporation](#) is a law firm specializing in plaintiff-side class actions. Waddell is a recognized class action leader, who has helped victims in a wide range of cases, including product liability, consumer protection, privacy breaches, franchise disputes, and securities misrepresentations.

The Team Members

- Sean Brown: sean@fmlaw.ca (416) 368-0231 x 230
- Candace Mak: cmak@fmlaw.ca (416) 368-0231 x 240

- Margaret Waddell: marg@waddellphillips.ca
(416) 477-6979
- Patti Shedden: patti@waddellphillips.ca
(416) 268-7033
- John-Otto Phillips: otto@waddellphillips.ca
(647) 313-1890

What is the Case About?

- This proposed class action seeks compensation for patients who were exposed to, or infected with the *M. chimaera* bacteria because a Stockert 3T Heater Cooler Unit (HCU) was used during the patient's open chest surgery.
- The Sorin Stöckert 3T Heater-Cooler Unit is typically used as a supporting device to a heart-lung machine (a machine that circulates blood and fluids to and from the patient). It is most frequently used during cardiac surgery, including open-heart surgery.

What is the Case About?

There are two water tanks inside the HCU. They can be heated or cooled. Hot-water and cold-water tubes lead from those tanks into a separate heat exchanger unit in a heart-lung machine. By providing heated or cooled water to the heart-lung machine, the HCU helps to increase or decrease the temperature of the patient's fluids circulating through the heart-lung machine when the patient is on cardiopulmonary bypass.

What is the Case About?

In this case, the water in some of the HCUs was contaminated, and the bacteria were aerosolized and travelled into the surgical field and landed in the surgical site.

If the bacteria got into the surgical site, it could cause an infection in the patient.

M chimaera infections are very hard to identify, because the symptoms are similar to many other symptoms from other diseases and infections. Also, it can take as long as 5 – 6 years for the infection to appear, although on average the infection does show up after about 18 months post-surgery.

What is the Case About?

- The claim alleges that Sorin Group Deutschland GMBH (Sorin) was negligent in:
 - how it designed the HCU;
 - allowing the HCUs to become infected with *M. chimaera* bacteria during the manufacturing process; and
 - In failing to provide proper warnings about the potential for patients to become exposed to the infection because of the tainted HCUs, and that their instructions for cleaning would not remove the *M. chimaera* bacteria from the machines

What is the Case About?

- In this case, there is a proposed Representative Plaintiff, Bruno Nardi, who has filed a Statement of Claim in Ontario, but for a National Class.
- Assuming the court certifies the class action, a notice will be published to all potential Class members, so that they are aware of the lawsuit and can decide whether they want to stay in or exclude themselves (opt out).
- When the class action is resolved – whether by a court approved settlement or a trial of the common issues – everyone in a class that has not opted out is bound by that resolution.

What is *M chimaera*?

M. chimaera is a species of the genus *Mycobacterium* falling within the subcategory of “non-tuberculous Mycobacterium” (NTM). belongs to the further subcategory of NTM, *Mycobacterium avium* complex (*M avium*). On the patient’s medical records, reference to any of NTM, *M avium*, or *M chimaera* is a first step in determining if the patient may have been, or was infected with *M chimaera*, particularly if there has been no conclusive diagnosis of an *M chimaera* infection.

M. chimaera is commonly found in the environment, such as in water and soil. But infection from *M. chimaera* in humans due to environmental contact is rare.

M. chimaera is exceedingly resilient and has a high level of resistance to antibiotics. Once it takes hold in a human host, it is very difficult to eradicate.

How the Infection Can Happen

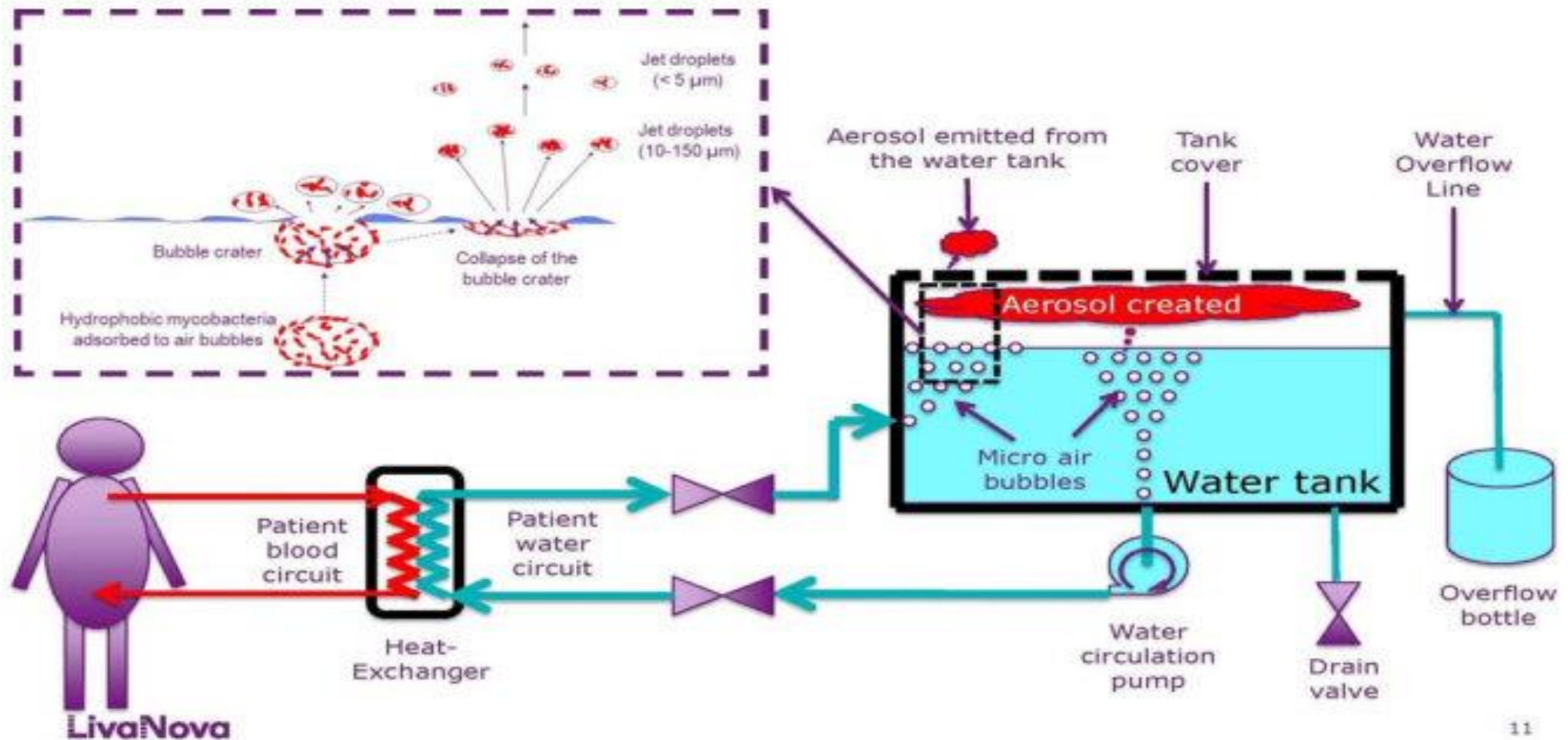

How the Infection Can Happen

A powerful fan blows air through the Device to regulate the temperature of the water tank and protect components of the HCU from overheating.

Because of the way the HCU is designed, the air from the fan blows over top of the water tanks, picking up water vapour. The vapour can contain any contaminants in the water tank, including aerosolized bacteria.

The HCUs contain tubing that is hard to clean. Both the tubing and the water tanks can develop a “biofilm” of bacteria and other contaminants that are common in even clean tap water, even when the machines were cleaned to the manufacturer’s specifications.

How the Infection Can Happen

By July 2011, Sorin knew that by using tap water in the tanks while at its manufacturing facility in Germany, the HCUs could become infected with bacteria and form a biofilm, and that there was a risk that the bacteria in the water droplets might be blown into the sterile surgical field; but Sorin kept manufacturing the HCUs with the same design.

Many of the HCUs were infected with a distinct form of *M. chimaera* bacteria at Sorin's manufacturing site. In a small number of cases, this bacteria got into patients' surgical sites, and has caused infection. The particular strain of *M. chimaera* that has been found in the 3T Devices is particularly hard to detect and difficult to treat, but it can be identified through special genetic testing.

Who can Participate in the Class Action?

This action is brought on behalf of:

- (a) All persons in Canada, who underwent surgery during which an HCU was used, during the period between January 1, 2010 and the date of certification of this action as a class proceeding; but excluding patients from the Institut de cardiologie de Montreal after January 1, 2012, (the “Patient Class”), and
- (b) Close family members of the Patient Class such as spouses and common law partners, children, grandchildren, parents, and grandparents (“Dependent Class”)

What is a class action?

- A class action is a type of lawsuit where one or more individuals sues one or more defendant on behalf of a group of people who have the same or similar injuries, arising from the same sort of wrong doing.
- There are 9 main steps that a class action may go through:
 1. The proposed Representative Plaintiffs file a Statement of Claim
 2. Motion to Certify (“Certification Motion”) the case as a class action
 3. Opt-out period, where anyone who meets the class definition but does not want to be included in the class action may exclude themselves
 4. Examinations for Discovery and exchange of documents – Representative Plaintiffs only

What is a class action?

5. Mediation (if the parties agree)
6. Settlement, which might happen at any time, if the parties agree. If there is a settlement, there will be court hearings for approval of the Settlement, and to approve counsel's fees
7. After a court grants Settlement Approval, the "Claims Administration" process can begin, during which class members may make claims for a portion of the settlement proceeds
8. If no settlement is reached, the case moves to a Trial on the common issues approved at the Certification Motion
9. If the Class' claims are not fully resolved at the Common Issues Trial, there will be individual issues trials to establish each Class member's claim

What does it mean to be a class member?

- **No upfront legal costs** – Class Counsel are paid on a contingency fee basis from the proceeds of a settlement or judgment
- **Shared costs of prosecuting the claims** – all the costs for expensive expert reports are paid upfront by the lawyers or the Class Proceedings Fund, and are repaid out of the settlement or judgment
- **Anonymity** – Class Members' names are not part of the court record, unless and until the individual claim stage
- **Compensation** for your injuries, without the need to start your own legal action, if the action is successful
- **Option to opt-out** if you do not wish to participate in the class action, and prefer to pursue your claims on your own. The choice does not have to be made until after the action is certified to proceed as a class proceeding.

How Long will it Take?

- Personal injury class action lawsuits can take a long time to reach a final resolution, particularly if the defendant opposes certification and engages in delay tactics, which is what we have experienced in this case. Actions may take as much as three to six years to complete.
- A number of factors can impact this timeline, particularly if the defendants change their tactics, and decide that they are willing to reach a fair and reasonable resolution of your claims.
- We now hope that our certification motion will be heard by the end of 2020, once the courts are back on track. If the motion is successful, it is possible that the defendants try to appeal that decision, which would cause a delay of up to another year before the case proceeds to the discovery phase.

How Much Compensation will I Get?

- It is always possible the case will not be successful, or that some Class Members' claims will not be established
- If the Class Action does succeed, it is too early to tell the value of the case, overall, as that will depend on how large the class is, and the extent of the Infected Class Members' injuries, the value that is placed upon the damages suffered by Class Members who either cannot prove their infection was *M chimaera*, or who only have been suffering from extraordinary anxiety while living with the fear that they have been infected, but the infection has not happened
- If a trial is required, first there will be 'common issues trial', possibly followed by Class Members having to prove their individual injuries and losses.
- Whether upon settlement or at trial, factors that typically affect compensation include:
 - How many class members make a claim to a settlement fund
 - What happened in each class member's individual circumstances
 - Litigation risk

How Much Compensation will I Get?

- The funds from any settlement are typically distributed according to the category into which each person falls, which can depend on such factors as, for example, the severity of their injuries.
- Any proposed compensation structure for class members will be approved by the Court, and it is the Court's responsibility to ensure that any settlement is fair and reasonable for the class as a whole.

What do I need to do to Participate?

- There is nothing further required from our Class Members right now
- We encourage Class Members to identify themselves to us, and provide details of their claim so that:
 - We can communicate directly with you
 - We can aggregate your experiences for the purposes of assessing the right amount of damages to claim in any further settlement discussions
 - We can help you to collect the documents to prove your losses
- We will send periodic updates about the case via email and posts on our websites
- There will also be direct notice according to Court Orders
- If you have information you think may be useful to the case, contact any of the lawyers directly

What do I need to do to Participate?

In our information sheet we have set out a long list of documents that will be needed to prove your individual claims.

DO NOT PANIC!!

These are the documents that we will ultimately need to establish the total amount of each class member's losses.

We do not need you to collect all this information right now, while we are in a state of emergency.

We will help you to collect the information once the action is certified as a class proceeding.

What do I need to do to Participate?

Information that we would like to know immediately:

1. Name of the Patient, and their health insurance number
2. Name of the Dependent class members (spouse or common law partners children, grandchildren, parents, and grandparents)
3. Hospital where the surgery took place, and when the surgery occurred
4. Whether there has been a confirmed diagnosis of *M chimaera* infection for the patient, and if so, when that diagnosis was made
 - We will contact you to learn about how the infection has impacted the patient's life and that of their loved ones.

What do I need to do to Participate?

Information that we would like to know immediately:

5. If the Patient has passed away.
 - We will be in touch with you to learn about how the loss of your loved one has affected the Dependent Class members, and to learn more about your loved one's illness from the infection after the surgery
6. If the Patient has not had a confirmed diagnosis of *M chimaera* infection, do they suspect that they have been infected, and if so, why?
7. If the Patient has not had a confirmed diagnosis of *M chimaera* infection, how has the knowledge of potential infection impacted on their day to day living?

Questions?

We are here to answer your questions any time.

You may contact any one of the team members to discuss your own particular case.

Now, if you have any questions that you would like to have answered, we would be pleased to answer them.

